



Tidewater Association of Service Contractors



**Rear Admiral Ned Deets
Commander
Naval Network Warfare Command
20 July 2011**



What You Can Do

- Situational Awareness
- Common Operational Picture
- Automation
- Defense Beyond the Firewall
- Baselining
- Anomaly Detection
- Integration of Enterprise Network Enclaves
- Bake IA into all new PORs/Systems





Information as a Weapon

“We must maintain our preeminence in networks, intelligence, and information. There is no other Service or nation that is as good as we are.”



***Admiral Gary Roughead
Chief of Naval Operations
17 July and 23 October 2009***

***“Aligning intelligence and operations and optimizing the network in many ways takes priority over the platform.
If we don’t get the intelligence and information right, then the platform is sub-optimized.
Therefore we need to elevate the priority of information. Since we already think and operate this way, it’s time aligned organizationally to sustain it ... to achieve prominence and dominance....”***

Information becomes a main battery of the U.S. Navy; this transition to an information-centric force represents a new vision of who we are as a seapower, as a Navy, and as warfare professionals



It is what it is....

- ...and it is a weapon system & all weapon systems are connected
- Non-kinetics may beat kinetics in the 21st century
- Business and admin systems have evolved into warfighting systems
- We can't function today without the Internet
 - *Our Millennials expect it*
 - *Our Millennials will use it to innovate and evolve cyber warfare*
 - *DoD users make 1 billion+ Internet connections every day*
- Convenience and security must be in balance





Challenge: Complex Networking Environment

- **Size --- 750,000 Users**
- **POR Vulnerabilities**
- **Reporting Processes**
- **Data Capture**
- **Data Visibility**
- **System Diversity**
- **Security**
- *Compatibility*
- *Platform centric acquisition*
- *Program alignment*
- *Install timelines*
- *Environment*
- *Training*
- *Finite manpower/Infinite demands*
- *Bandwidth-data choke point*
- *Life cycle costs*

Enterprise 62%

NIPR*

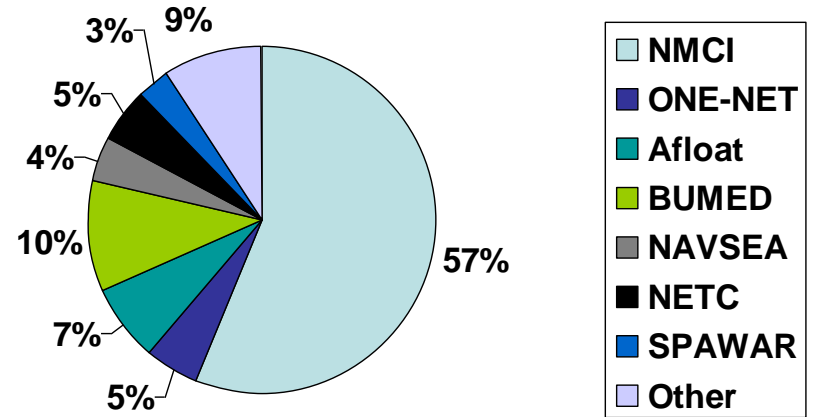

Non-Enterprise 38%

Total Assets ~ 448K

SIPR*

Enterprise 41%

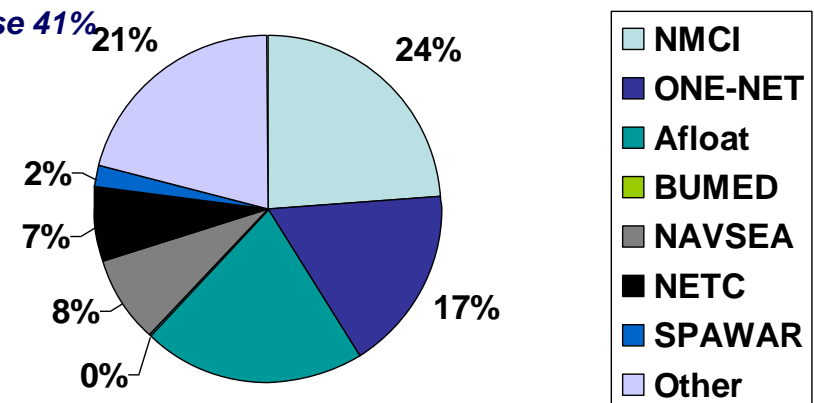

Non-Enterprise 59%

Total Assets ~ 57K

* As of 1 Mar 11



Cyber Asset Reduction and Security (CARS) Achievements

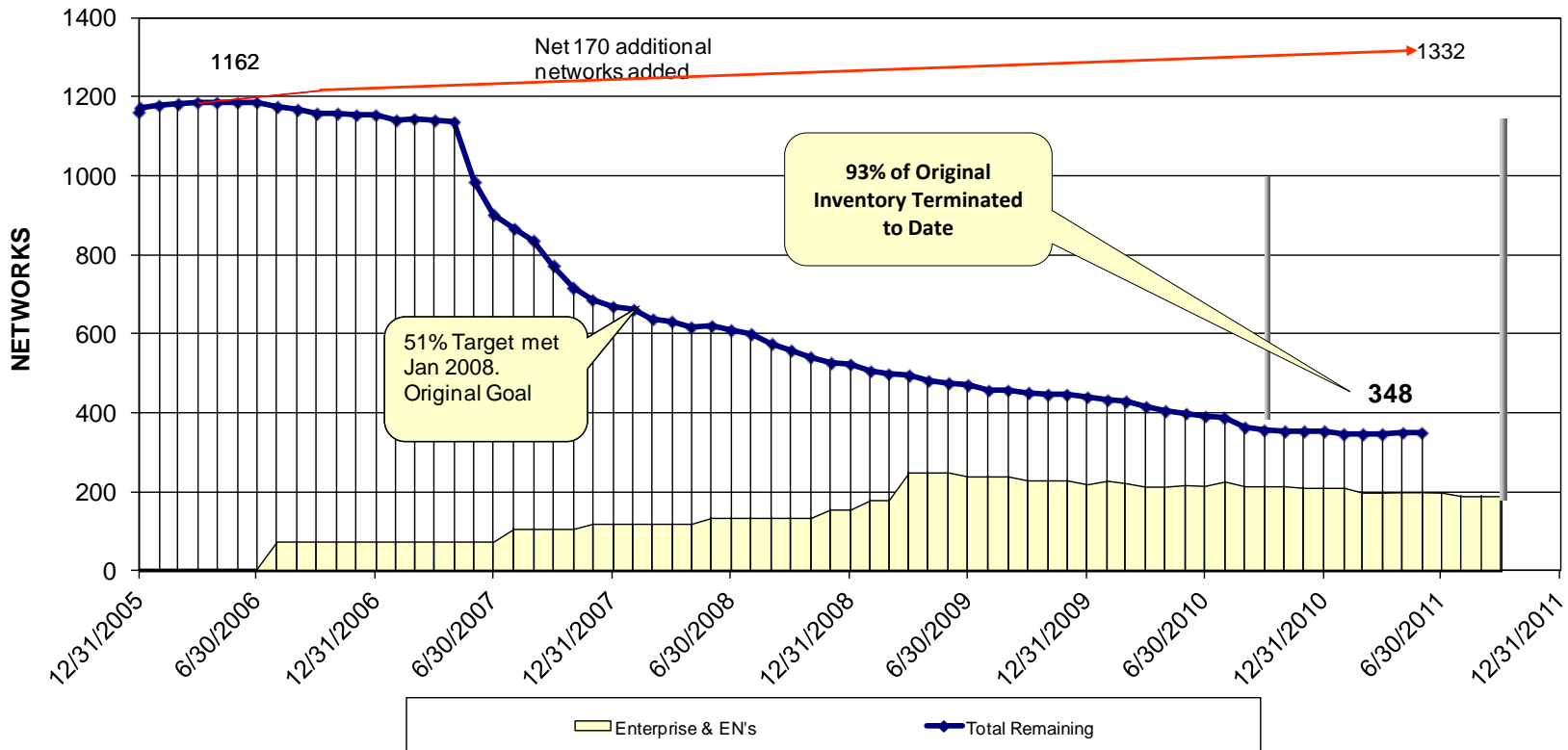

Initial Goal: Reduce Network Portfolio by 51%

Network Reductions: 984

Server Reductions: 19,477

Device Reductions: 32,208



Verizon Data Breach Study

How do breaches occur?

“Due to the lower proportion of internal threat agents, “Misuse” lost its pole position among the list of threat action categories. Hacking and Malware have retaken the lead and are playing dirtier than ever. Absent, weak, and stolen credentials are careening out of control. Gaining quickly... .. - Physical.”

- 50%** - Utilized some form of hacking (+10%)
- 49%** - Incorporated malware (+11%)
- 29%** - Involved physical attacks (+14%)
- 17%** - Resulted from privilege misuse (-31%)
- 11%** - Employed social tactics (-17%)

Source

2011 Data Breach Investigations Report



What commonalities exist?

“Breaching organizations still doesn't typically require highly sophisticated attacks, most victims are a target of opportunity rather than choice, the majority of data is stolen from servers, victims usually don't know about their breach until a third party notifies them, and almost all breaches are avoidable (at least in hindsight) without difficult or expensive corrective action. “

- 83%** of victims were targets of opportunity (+-0)
- 92%** of attacks were not highly difficult (+7%)
- 76%** of all data was compromised from servers (-22%)
- 86%** were discovered by a third party (+25%)
- 96%** of breaches were avoidable (+-0)

A study conducted by the Verizon RISK Team with cooperation from the U.S. Secret Service and the Dutch High Tech Crime Unit



Challenge: Exposure

Top 20 Sites Visited by Navy Users (May 2011)

Domain	Description
1 google.com (High BW)	YouTube and Google Video
2 google.com (Low BW)	Search, Email and Maps
3 pandora.com	Internet Radio
4 streamtheworld.com	Streaming Radio (Including CBS Radio)
5 facebook.com	Social Networking
6 yahoo.com	Search Engine, Portal, News, Personal E-
7 amazon.com	Shopping
8 wordpress.com	Blog Hosting
9 microsoft.com	Software and Software Updates
10 CNN	News
11 verisign.com	PKI and Encryption
12 msn.com	News, Portal
13 live365.com	Internet Radio
14 craigslist.org	Shopping
15 ebay.com	Online Auctions, Shopping
16 windowsupdate.com	Software Updates
17 blackboard.com	Educational Software
18 usmc-mccs.org	Marine Corps Community Services
19 wikipedia.org	Reference
20 navyfcu.org	Banking/Financial

Internet traffic grows reliably at a 39% annual rate

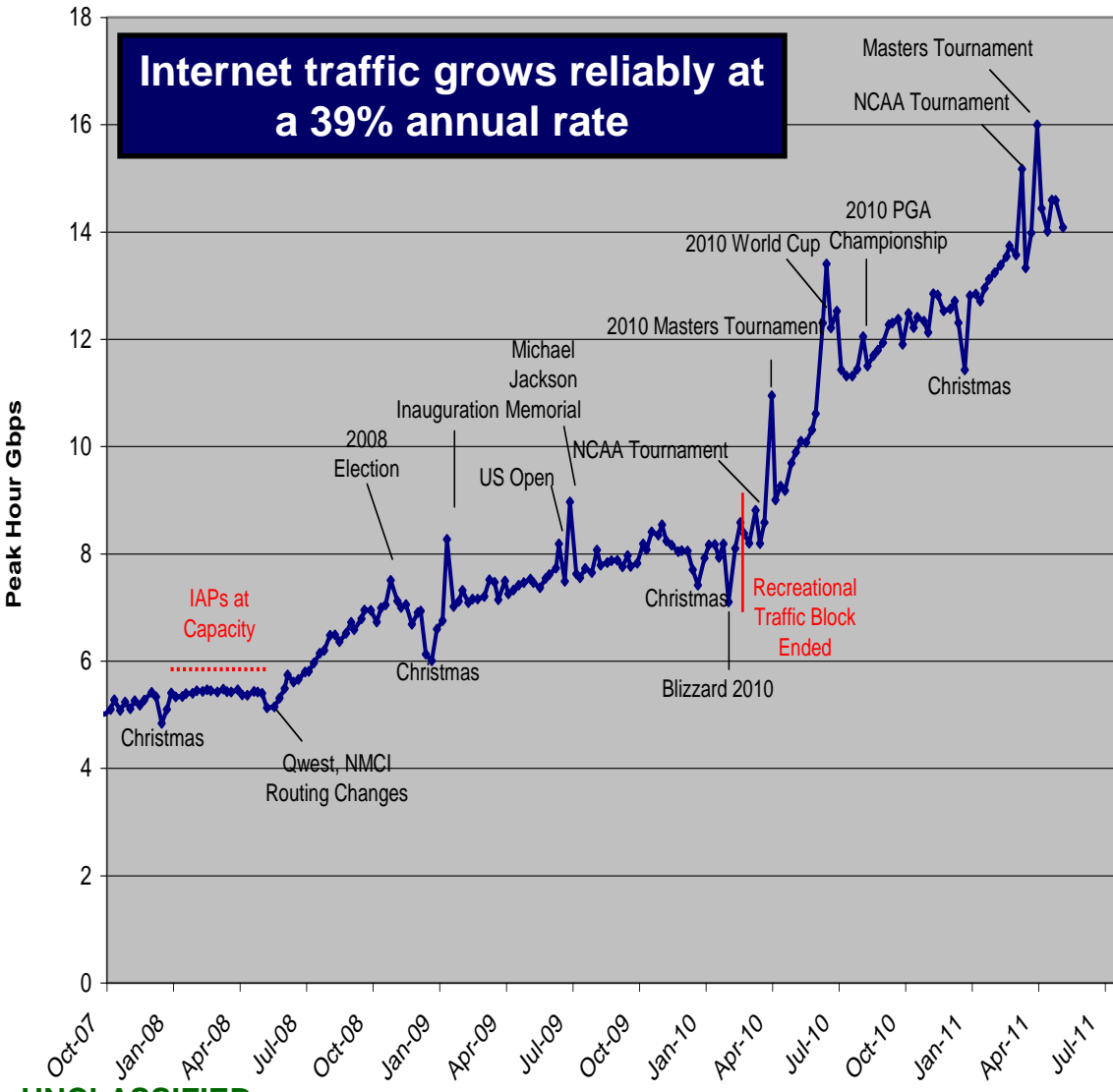



Social Networking -What's the Risk?



Risk is acknowledged

“So we’ve joined that conversation.....”

We’re burning the boats. There’s no going back. We’re committed irreversibly (to Social Networking).”

CNO Roughead (May 2011)





The Cyber COP

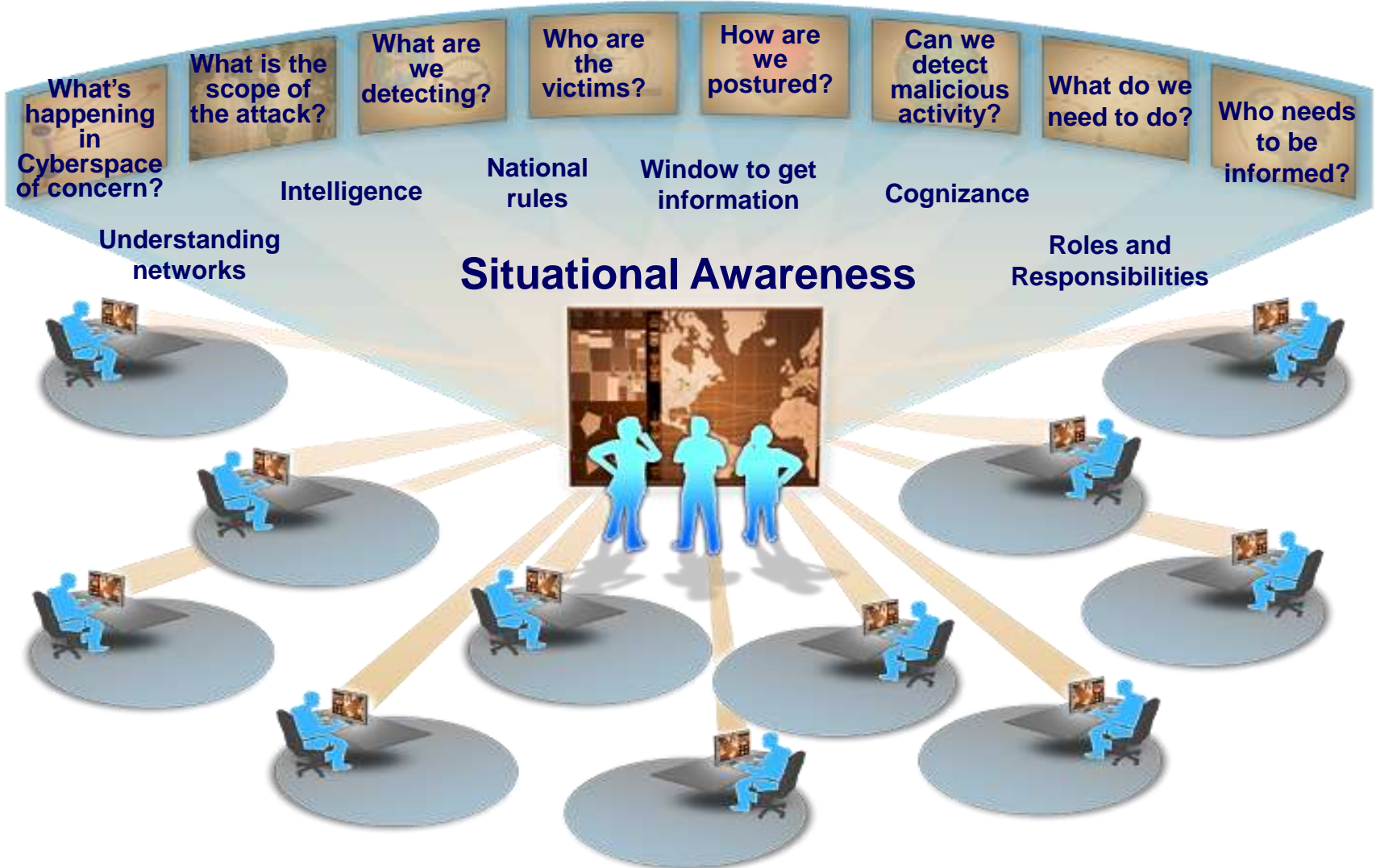



Accountability for Network Security



COMUSFLTFORCOM 261555Z May 09

(U) LET ME BE CLEAR. IT IS YOUR RESPONSIBILITY TO PROTECT YOUR NETWORK AND PRECLUDE THIS SORT OF ACTIVITY. DOD AND NAVY POLICY EXPRESSLY PROHIBIT THE USE OF THUMB DRIVES ON DOD COMPUTERS. IPODS, PERSONAL BLACKBERRIES, AND CELL PHONES ARE STORAGE DEVICES AND MAY NOT BE PLUGGED INTO A NAVY COMPUTER, EVEN FOR CHARGING. THESE STORAGE DEVICES CAN CARRY MALWARE AND SPREAD INFECTIONS.



**Admiral Jonathon W. Greenert
Commander
U.S. Fleet Forces
Sep 07 – Jul 09**



Inspections

Situational Awareness

**COMFLTCYBERCOM
FT GEORGE G MEADE MD
282138Z JAN 11**



***“A COORDINATED COMPACTFLT, USFF,
AND COMFLTCYBERCOM MESSAGE.***

***IMPLEMENT CNO DIRECTED CYBER
SECURITY INSPECTION AND
CERTIFICATION PROGRAM (CSICP).”***

***“THE PROGRAM WILL ENSURE HEALTH
AND SECURITY OF NAVY NETWORKS
AND CONNECTED COMBAT SYSTEMS.”***

***“NAVY NETWORKS ARE A COMBAT
SYSTEM AND WILL ADHERE TO THE
SAME INSPECTION AND CERTIFICATION
RIGOR AS ALL OTHER COMBAT
SYSTEMS.”***



Achieving C2

Network Command & Control (C2) is the exercise of authority and direction by a properly designated commander over assigned and attached forces in the accomplishment of the mission. Network C2 functions are executed through an arrangement of personnel, equipment, communications, facilities, and procedures employed by a commander in planning, directing, coordinating, and controlling forces and operations in the accomplishment of the mission. Situational awareness is implicit within C2 since it is not possible to appropriately exercise C2 without an understanding of the status of assigned forces.



Largest, Most Mature Network Forcing Function for Achieving C2 of all Navy Networks



Operational Alignment For C2

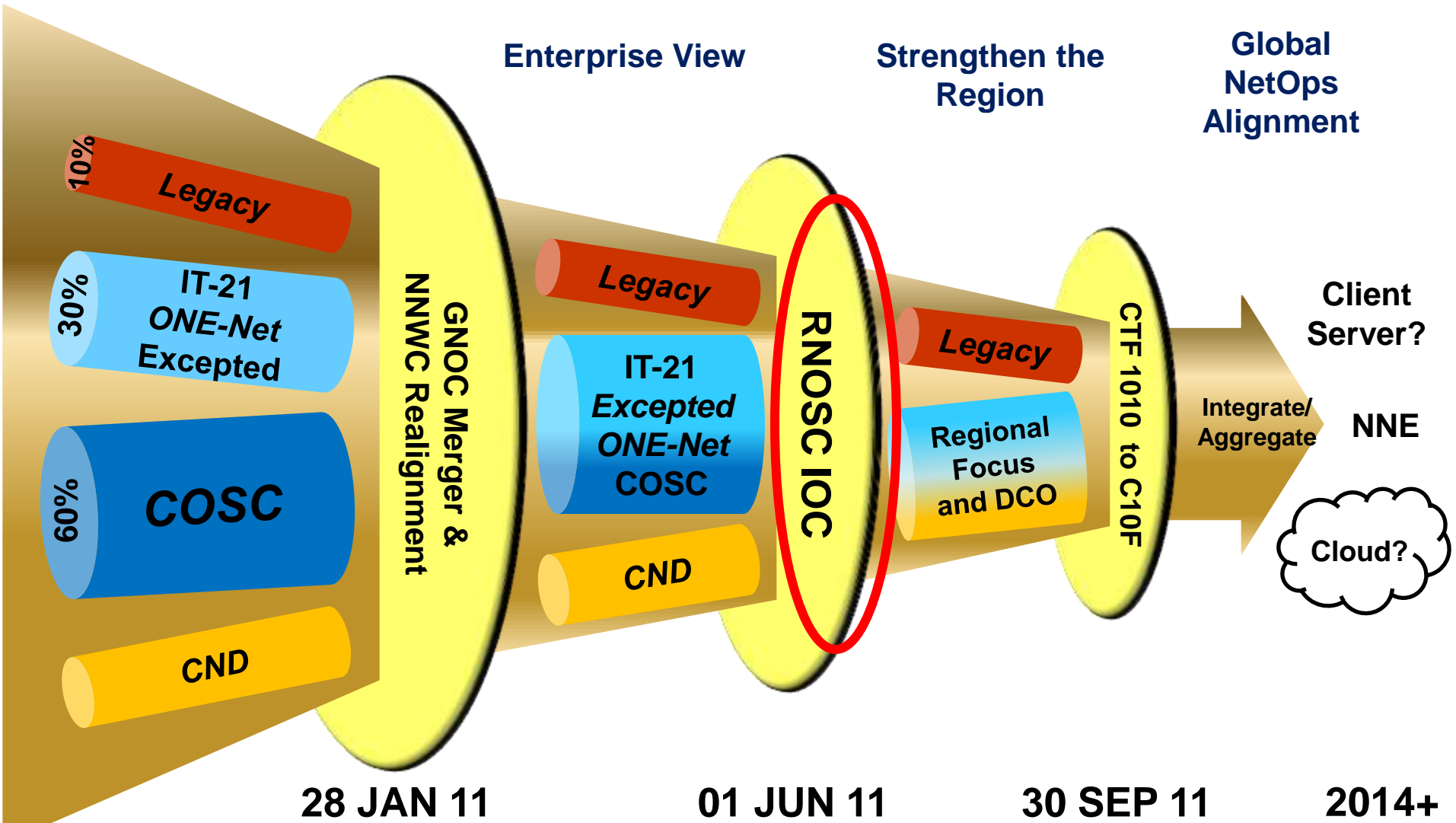



Regional Network Operations and Security Command (RNOSC) C2

UNCLASSIFIED



Regional CDR:

- Comply w/Global Orders
- Impact limited to AOR
- Report to CTF 1010 ASAP
- ** Ops Urgency Prevails

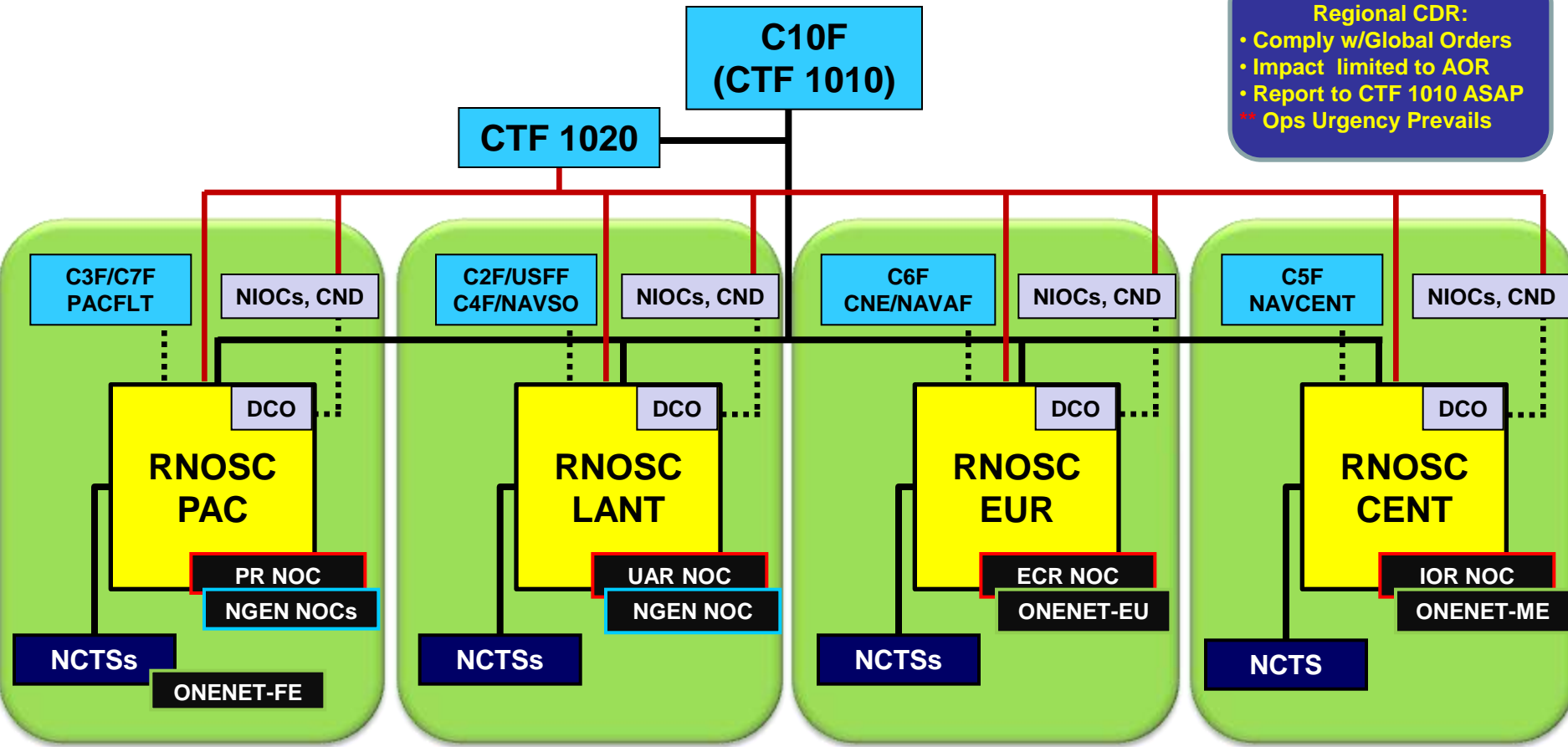

— Command – lawful command authority over subordinates by assignment or rank
 — Control – non-command authority exercised over activities of organizations
 Coordinate – delegated authority for coordinating specific functions or activities

UNCLASSIFIED



What You Can Do

- Situational Awareness
- Common Operational Picture
- Automation
- Defense Beyond the Firewall
- Baselining
- Anomaly Detection
- Integration of Enterprise Network Enclaves
- Bake IA into all new PORs/Systems



Questions?

RADM Ned Deets

Edward.Deets@navy.mil

(757) 417-6700